

GalvinAssist[®] CP Hand Shower Kit w/ Hygienic G/Rail, ClevaCare[®] Shower



PRODUCT CODES:

- CLEVA045CP



SPECIFICATIONS

- The ClevaCare[®] Shower Arm is suitable for new or retrofit installations.
- CP Brass swing arm with stainless steel spring.
- Supplied with stainless steel fasteners.
- Finished in bright chrome plate for easy cleaning and added durability.

IMPORTANT: All Galvin Engineering taps are tested in accordance with AS/NZS 3662 and leave our premises in good working order.

TECHNICAL DATA

Inlet	1/2" BSP – Female	
Outlet	Handheld Shower	
Headwork	N/A	
Working Pressure Range (kPa)	Min	150
	Max	500
Working Temperature Range (°C)	Min	5
	Max	55
Nominal Flow Rate (LPM)	8.24	
Construction	Brass	
Finish	Chrome	

The shower may not be suitable for use in gravity-fed water heaters, low pressure supply networks, instantaneous water heaters, tempering valves and thermostatic mixing valves. (AS3662-2013). For use with potable water only. Not suitable for low or unequal pressure water supply.

NOTE: Galvin Specialised continually strive to improve their products. Specifications may change without notice.

TOOLS REQUIRED

- Power drill
- Spanner or adjustable crescent

PRE-INSTALLATION

MOUNTING DETAILS

- If the mounting holes do not already exist, mark out and drill the holes as shown in rough-in dimensions.

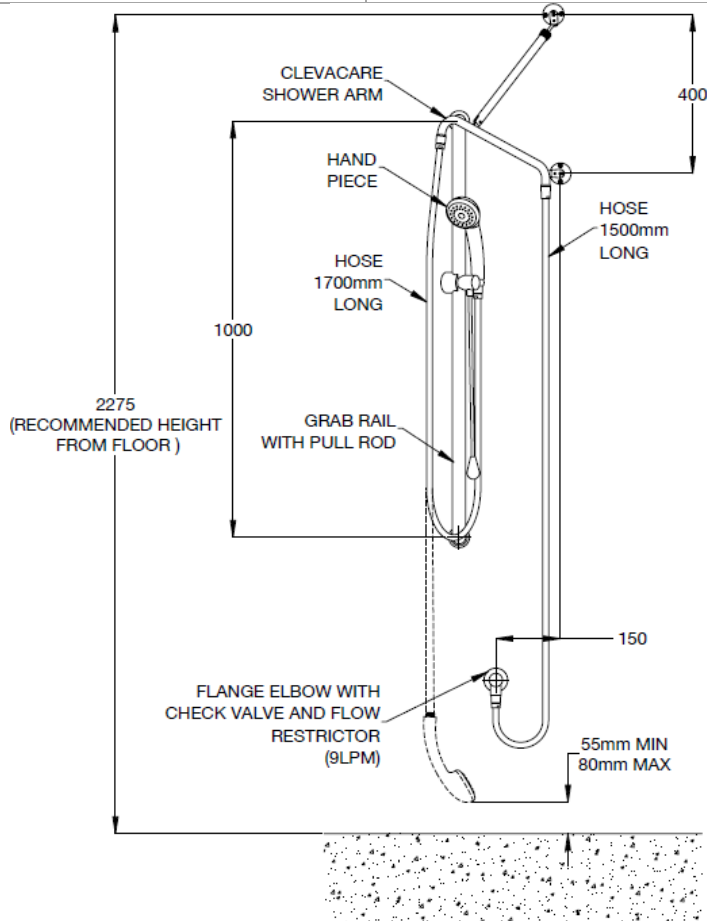
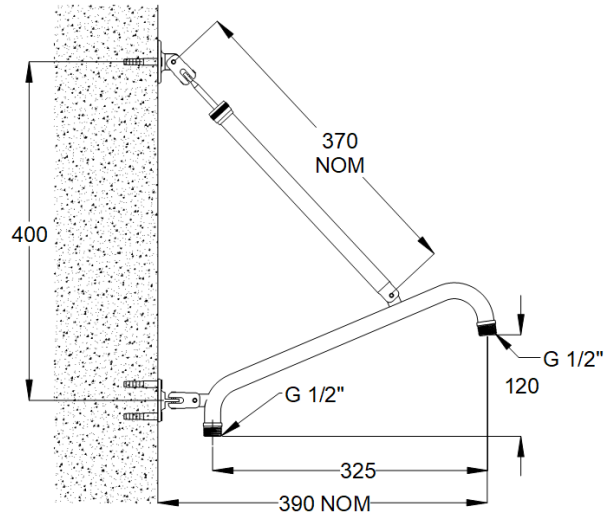
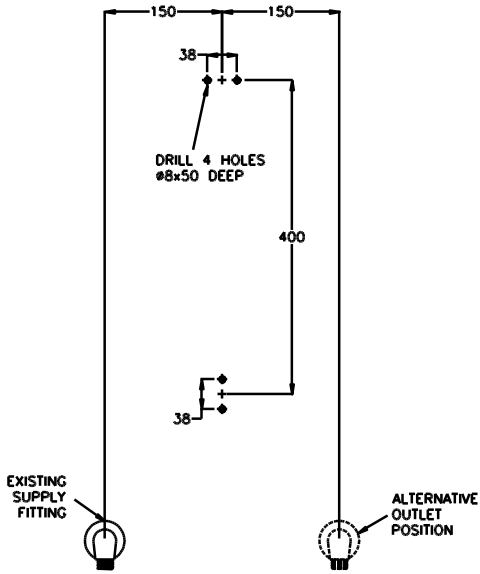

INSTALLATION

INSTALLATION COMPLIANCE: Galvin Engineering products must be installed in accordance with these installation instructions and in accordance with AS/NZS 3500, the PCA and your local regulatory requirements. Water and/or electrical supply conditions must also comply to the applicable national and/or state standards. Failing to comply with these provisions shall void the product warranty and may affect the performance of the product.

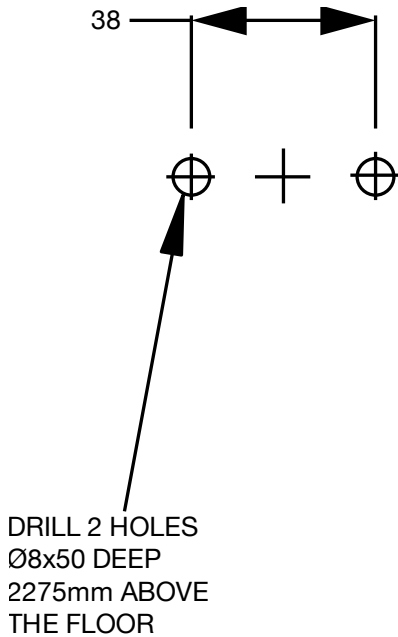

1. Top Flange

Mark the height of the top flange centre point by measuring vertically 2275mm above the floor. Then measure approximately 150mm horizontally to the left or right (depending on the position of the shower recess) of the centre of the existing supply fitting. Drill 2 holes Ø8 x 50mm deep, 38mm horizontally apart to suit the top flange.

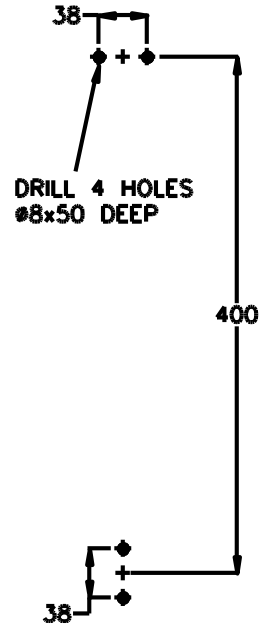

2. Bottom Flange

Mark the position of the bottom flange's centre point 400mm below the top flange's centre point. Then mark the two holes for mounting the bottom flange similar to the manner as the top flange.

Note: The bottom flange is mounted in a vertical orientation.

Important: the functionality of this product relies on the accuracy of the vertical alignment between the top and bottom flanges.

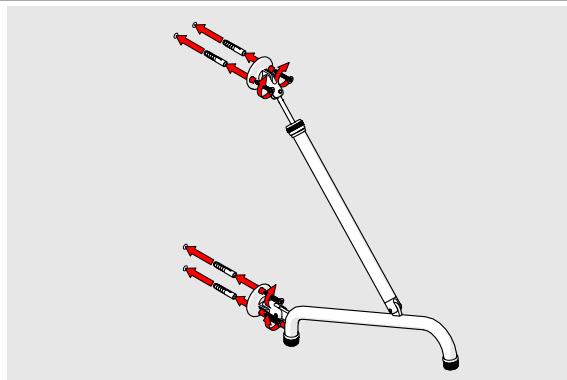

3. Mount the shower arm

Attach both the wall flanges using the plastic star plugs and self-tapping screws supplied (these fasteners may not be appropriate for all wall materials. If this is the case, other fastening systems will have to be sourced by the installer).

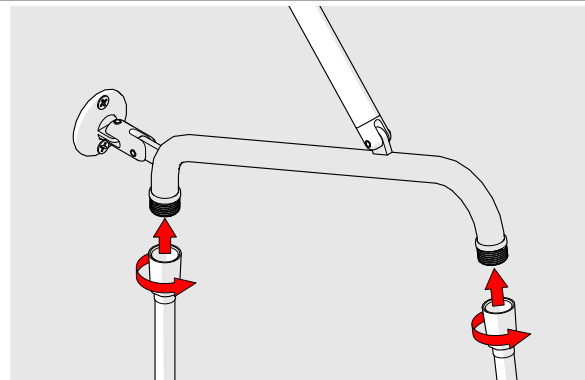

4. Attach the hose

When fitting the inlet hose, lay the arm against the wall in the preferred 'resting' position, then tighten the hose. The arm will tend to return to this position when not in use.

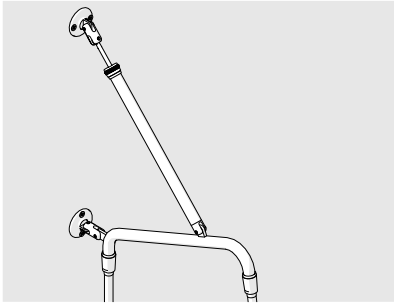

5. Check Shower for operation and leaks

Check the hose is securely connected. Turn on water supply, the shower should now be working. Once installation is completed, the unit must be tested for any leaks.

Notes:

1. To comply with backflow prevention standards, the hand spray must hang at least 55mm above the floor providing an 'air-gap'. If the hand piece lies on the floor, then an appropriate backflow prevention device must be installed.
2. Shown is a Clevakit typical installation conforming to AS1428.1-2009.

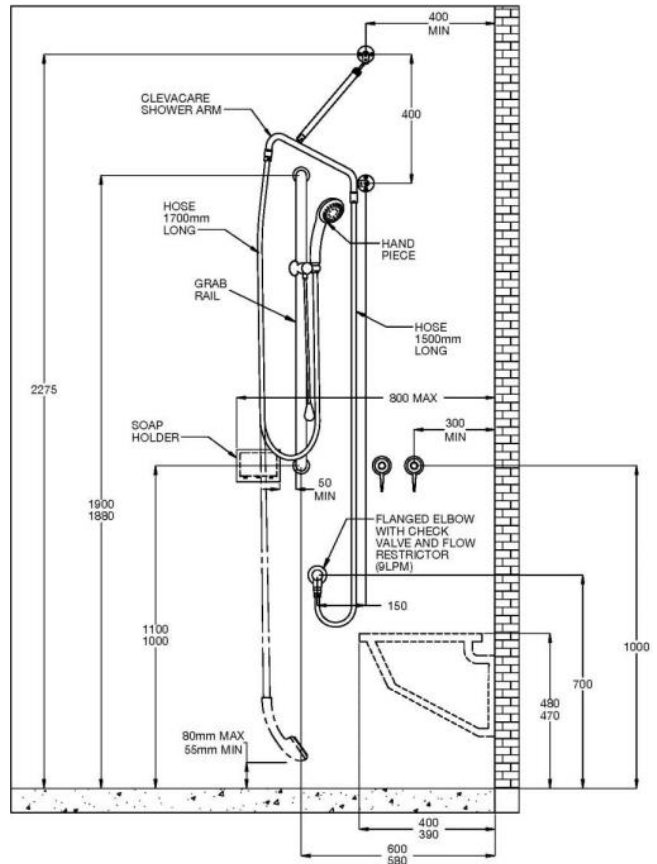

Clevakit typical installation
Conforming to AS1428.1-2009

TROUBLESHOOTING

PROBLEM	CAUSE	RECTIFICATION
Water is not flowing or inconsistent flow	Shower arm is blocked with debris.	Remove debris from shower arm.
Leak from hose connection	Hose connection loose	Check wall coupling locates properly with hose connection.

WARRANTY

The warranty set forth herein is given expressly and is the only warranty given by the Galvin Engineering Pty Ltd. With respect to the product, Galvin Engineering Pty Ltd makes no other warranties, express or implied. Galvin Engineering Pty. Ltd. hereby specifically disclaims all other warranties, express or implied, including but not limited to the implied warranties of merchantability and fitness for a particular purpose.

Galvin Engineering Pty Ltd products are covered under our manufacturer’s warranty available for download from www.galvinengineering.com.au Galvin Engineering Pty Ltd expressly warrants that the product is free from operational defects in workmanship and materials for the warranty period as shown on the schedule in the manufacturer’s warranty. During the warranty period, Galvin Engineering will replace or repair any defective products manufactured by Galvin Engineering without charge, so long as the terms of the Manufacturer’s warranty are complied with.

The remedy described in the first paragraph of this warranty shall constitute the sole and exclusive remedy for breach of warranty, and Galvin Engineering Pty Ltd shall not be responsible for any incidental, special or consequential damages, including without limitation, lost profits or the cost of repairing or replacing other property which is damaged if this product does not work properly, other costs resulting from labour charges, delays, vandalism, negligence, fouling caused by foreign material, damage from adverse water conditions, chemical, electrical or any other circumstances over which Galvin Engineering has no control. This warranty shall be invalidated by any abuse, misuse, misapplication, improper installation or improper maintenance or alteration of the product.